

# 10.

---

## Counting

---

- The multiplication principle
- Factorials
- Combinations
- ${}^n C_r$  and Pascal's triangle
- More about Pascal's triangle
- Miscellaneous exercise ten

Note: Students who are also studying *Mathematics Specialist* will already be familiar with some of the concepts covered in this chapter.

## Situation

A teacher sets her class the challenge of coming up with as many words as they can using some or all of the letters in the word CONSIDER.

Each word has to

- be a proper word that can be found in a dictionary, and
- be of at least 4 letters, and
- have no repeat letters (as the letters in the word CONSIDER each appear only once).  
Thus words like NONE (2Ns), DRESS (2 Ss) and DECIDER (2 Ds and 2Es) are not allowed.

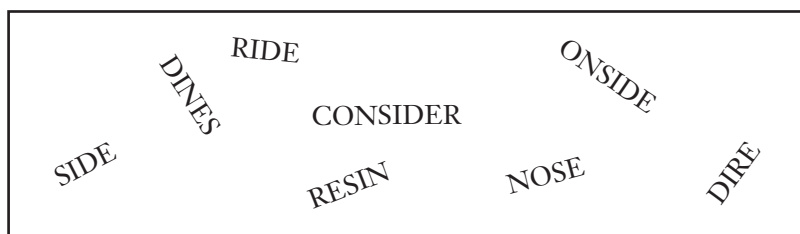

One of the students in the class thought that he would first make a list of **all** the ‘words’ of four or more letters from the letters in the word CONSIDER, including those that might not be found in a dictionary. Then, using the spell checker on a computer to determine if such a word was a ‘real’ word, he would cross out any ‘illegal’ words from the list to end up with his final list.

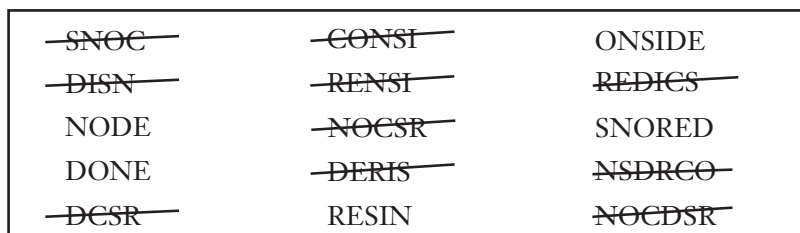

Try to work out (or at least make some estimate of) how many ‘words’ would be on the student’s list for the spell checker to check.

Hint: Whilst one-, two- and three-letter words are not allowed you might like to consider these situations first in an attempt to establish patterns and techniques that could then be extended to words with four or more letters.

How did you get on with the situation on the previous page? With so many possible 'words' on the student's list it would take a long time if we attempted to count how many there were by first listing them all. Instead we need other ways of determining how many possibilities there are without having to list them all first.

Contrast this to some of the questions in the previous chapter where we did indeed list all of the equally likely outcomes in order to determine probabilities.

Had the situation of the previous page simply involved all possible four-letter words made from a four-letter word, say STEP, we could well have listed all 'words', perhaps in the form of a tree diagram, as shown on the right.

However, with CONSIDER, an eight-letter word, and with four-, five-, six-, seven- and eight-letter words allowed, determining how many 'words' there are by listing would take a long time.

To avoid having to do this we develop techniques for counting the number of possible *arrangements* there are of the letters without having to list them all. Hence the title of this chapter, *Counting*.

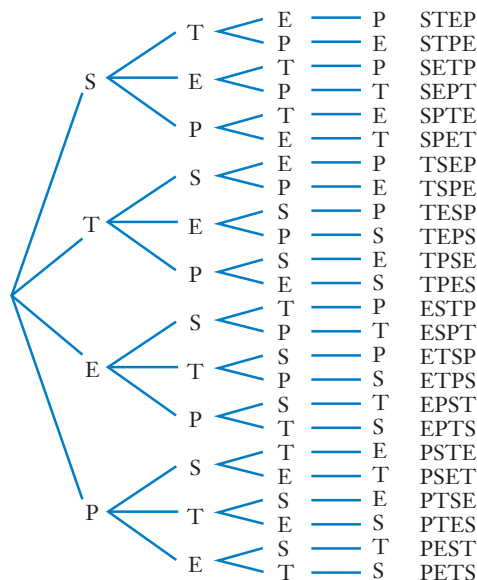

Note in the above tree diagram we have  
 Having chosen the first letter we then have  
 With the first and second chosen we then have  
 With first, second and third chosen we have

4 choices of first letter: S, T, E, P.  
 3 choices of second letter.  
 2 choices of third letter.  
 1 choice for the final letter.

$$\begin{aligned} \text{Total number of choices} &= 4 \times 3 \times 2 \times 1 \\ &= 24. \end{aligned}$$

We have obtained the number of possible arrangements using *multiplicative reasoning*. This reasoning is formalised in the *multiplication principle*.

## The multiplication principle

If there are  $a$  ways an activity can be performed, and for each of these there are  $b$  ways that a second activity can be performed after the first, and for each of these there are  $c$  ways that a third activity can be performed after the second, and so on, then there are  $a \times b \times c \times \dots$  ways of performing the successive activities.

By appropriately choosing the successive operations we can use this rule to determine the total number of seven-letter 'words' that can be formed using all of the letters of, for example, the word NUMBERS:

The first letter can be chosen in 7 ways, the second can then be chosen in 6 ways, the third in 5 ways etc.

$$\begin{aligned} \text{Total number of words} &= 7 \times 6 \times 5 \times 4 \times 3 \times 2 \times 1 \\ &= 5040. \end{aligned}$$

No. of ways for each letter						
7	6	5	4	3	2	1



Ordered and unordered selections

# Factorials

Use of the multiplication principle frequently involves us in evaluating expressions like:

$$\begin{aligned}
 &2 \times 1 \\
 &3 \times 2 \times 1 \\
 &4 \times 3 \times 2 \times 1 \\
 &5 \times 4 \times 3 \times 2 \times 1 \\
 &6 \times 5 \times 4 \times 3 \times 2 \times 1 \text{ etc.}
 \end{aligned}$$

We write  $n!$ , pronounced '***n* factorial**', to represent

$$n \times (n-1) \times (n-2) \times \dots \times 3 \times 2 \times 1 \text{ where } n \text{ is a positive integer.}$$

For example

$$\begin{aligned}
 3! &= 3 \times 2 \times 1 \\
 &= 6 \\
 5! &= 5 \times 4 \times 3 \times 2 \times 1 \\
 &= 120 \\
 10! &= 10 \times 9 \times 8 \times 7 \times 6 \times 5 \times 4 \times 3 \times 2 \times 1 \\
 &= 3\,628\,800
 \end{aligned}$$

3!	6
5!	120
10!	3628800

## EXAMPLE 1

Evaluate

**a**  $6!$

**b**  $5! \div 3!$

**c**  $100! \div 98!$

### Solution

**a**  $6! = 6 \times 5 \times 4 \times 3 \times 2 \times 1$   
 $= 720$

**b**  $5! \div 3! = \frac{5 \times 4 \times 3!}{3!}$   
 $= 5 \times 4$   
 $= 20$

**c**  $100! \div 98! = \frac{100 \times 99 \times 98!}{98!}$   
 $= 100 \times 99$   
 $= 9\,900$

Now suppose we have 5 objects, all different, that we will call a, b, c, d and e.

We are going to put three of these objects in a row, for example, c e a.

How many different *arrangements* are there of three objects when the three can be chosen from 5 different objects?

Again we could list the possible arrangements:

abc	abd	abe	acd	ace	ade	bcd	bce	bde	cde
acb	adb	aeb	adc	aec	aed	bdc	bec	bed	ced
bac	bad	bae	cad	cae	dae	cbd	cbe	dbe	dce
bca	bda	bea	cda	cea	dea	cdb	ceb	deb	dec
cab	dab	eab	dac	eac	ead	dbc	ebc	ebd	ecd
cba	dba	eba	dca	eca	eda	dcb	ecb	edb	edc

to arrive at an answer of 60 but again use of the multiplication principle makes the counting process much easier:

$$\begin{aligned} \text{Number of arrangements} &= 5 \times 4 \times 3 \\ &= 60 \end{aligned}$$

No. of ways for each letter		
1st	2nd	3rd
5	4	3

In this case the number of arrangements is not  $5!$  but instead  $\frac{5!}{2!}$ .

Thus:

Whilst the number of arrangements of  $n$  different objects is  $n!$ ,  
the number of arrangements of  $r$  objects chosen from  $n$  different objects is

$$\frac{n!}{(n-r)!}$$

For example, the number of arrangements of two different letters that can be made when the two letters can themselves be chosen from the five letters a, b, c, d, e is

$$\begin{aligned} \frac{5!}{(5-2)!} &= \frac{5!}{3!} \\ &= 5 \times 4 \\ &= 20 \end{aligned}$$

as we would expect from the multiplication principle.

Note: An arrangement is sometimes referred to as a **permutation**.

### Exercise 10A

Evaluate:

**1**  $8!$

**2**  $4! \times 2!$

**3**  $10! \div 9!$

**4**  $10! \div 8!$

**5**  $\frac{90!}{89!}$

**6**  $\frac{8!}{6!}$

**7**  $3! + 2!$

**8**  $\frac{100!}{97!}$

**9**  $5! - 4!$



Express each of the following both numerically and using factorial notation.

- 10 The number of five letter arrangements there are of the letters of the word MATHS.
- 11 The number of two different letter arrangements there are when the two letters can themselves be chosen from the letters of the word MATHS.
- 12 The number of three different letter arrangements there are when the three letters can themselves be chosen from the letters of the word MATHS.
- 13 The number of two letter codes there are if the two letters are to be chosen from the 26 letters of the alphabet and the code must involve two different letters.
- 14 The number of four letter codes there are if the four letters are to be chosen from the 26 letters of the alphabet and the code must involve four different letters.
- 15 The number of permutations there are of the eight letters of the word FORECAST (each letter used once in each permutation).
- 16 How many permutations there are, each involving three different digits, if the three digits can themselves be chosen from the set  $\{1, 2, 3, 4, 5, 6, 7, 8, 9\}$ .

## Combinations

Suppose we are given a box of chocolates. We would expect the box to contain a **selection** of chocolates. The way the chocolates were arranged or ordered in the box probably would not concern us too much. If we were to arrange the chocolates differently in the box, or perhaps even empty all of the chocolates into a bag, we would still have the same selection of chocolates.

The arrangement may have changed but the selection is still the same.



A **combination** is a selection — the order does not matter.

A permutation is an arrangement — the order does matter.

Thus, whilst there are 60 possible arrangements, or permutations, of three letters taken from the set  $\{a, b, c, d, e\}$ :

abc	abd	abe	acd	ace	ade	bcd	bce	bde	cde
acb	adb	aeb	adc	aec	aed	bdc	bec	bed	ced
bac	bad	bae	cad	cae	dae	cbd	cbe	dbe	dce
bca	bda	bea	cda	cea	dea	cdb	ceb	deb	dec
cab	dab	eab	dac	eac	ead	dbc	ebc	ebd	ecd
cba	dba	eba	dca	eca	eda	dcb	ecb	edb	edc

there are just 10 selections, or **combinations**, of three different letters taken from the set  $\{a, b, c, d, e\}$ :

abc	abd	abe	acd	ace	ade	bcd	bce	bde	cde
-----	-----	-----	-----	-----	-----	-----	-----	-----	-----

Notice that to determine the number of **combinations** of three different letters taken from the set {a, b, c, d, e} we had to divide the number of arrangements by  $3!$ , the number of ways of arranging each set of three letters.

Similarly, to determine the number of combinations of  $r$  different objects taken from  $n$  different objects we divide the number of arrangements by  $r!$

But the number of **arrangements** of  $r$  different objects taken from  $n$  different objects is

$$\frac{n!}{(n-r)!}$$

Thus the number of **combinations** of  $r$  different objects taken from a set containing  $n$  different objects will be

$$\frac{n!}{(n-r)! r!}$$

We use the notation  ${}^n C_r$  for the number of combinations of  $r$  different objects taken from a set containing  $n$  different objects.

There are  ${}^n C_r$  combinations of  $r$  objects chosen from  $n$  different objects where

$${}^n C_r = \frac{n!}{(n-r)! r!}$$

Thus the number of combinations of three objects chosen from five different objects will be

$$\begin{aligned} {}^5 C_3 &= \frac{5!}{(5-3)! 3!} \\ &= \frac{5!}{2! 3!} \\ &= \frac{5 \times 4}{2 \times 1} \\ &= 10 \end{aligned}$$

which agrees with our listing on the previous page of the number of combinations of three letters taken from the set {a, b, c, d, e}.

Many calculators can, given the values of  $n$  and  $r$ , determine  ${}^n C_r$ .

Get to know how to use your calculator in this regard and use it to confirm the previous answer,  ${}^5 C_3 = 10$ , and that  ${}^8 C_3 = 56$ ,  ${}^{10} C_4 = 210$ ,  ${}^{40} C_7 = 18\,643\,560$ .

${}^8 C_3$	56
$\text{nCr}(8,3)$	56

## EXAMPLE 2

How many combinations are there of 2 objects chosen from five different objects?

### Solution

$$\begin{aligned}\text{Number of combinations} &= {}^5C_2 \\ &= \frac{5!}{(5-2)! 2!} \\ &= \frac{5!}{3! 2!} \\ &= 10\end{aligned}$$

$$\text{nCr}(5,2) \qquad 10$$

If we label the five objects as A, B, C, D and E, the ten combinations are:

AB, AC, AD, AE,  
BC, BD, BE,  
CD, CE,  
DE.

- Note:
- ${}^nC_r$  is also written  $\binom{n}{r}$ . For example  $\binom{7}{2} = {}^7C_2$ .
  - ${}^nC_r$  can be thought of as ‘from  $n$  choose  $r$ ’.

## EXAMPLE 3

A bowl of fruit contains one of each of eight different types of fruit. Parri wants to choose three items of fruit from the bowl to take to school. How many different combinations of three items are possible?

### Solution

From 8

Choose 3

$$\begin{aligned}\text{Number of combinations} &= \binom{8}{3} \\ &= \frac{8!}{(8-3)! 3!} \\ &= \frac{8!}{5! 3!} \\ &= 56\end{aligned}$$

$$\text{nCr}(8,3) \qquad 56$$



### EXAMPLE 4

From a committee of 20 people a subgroup of 4 is to be formed. How many different subgroups are possible?

#### Solution

From 20

Choose 4

$$\begin{aligned}\text{Number of combinations} &= {}^{20}C_4 \\ &= \frac{20!}{(20-4)! 4!} \\ &= \frac{20!}{16! 4!} \\ &= 4845\end{aligned}$$

$${}^{n}C_r(20,4)$$

$$4845$$

### Exercise 10B

- 1 How many combinations of four shirts to take on a holiday can be made from the 11 shirts available?
- 2 Members of a wine club are invited to select twelve different bottles of wine from a list of 18 wines. How many different selections are possible?
- 3 A newspaper editor has 10 pictures available to accompany an article about fishing. He wishes to choose six. How many different selections are possible?
- 4 How many selections of 3 chocolates can be made from 15 different chocolates?
- 5 From a committee of 12 people a subgroup of 5 is to be formed to represent the committee at a particular function. How many different such subgroups are possible?
- 6 For many games of cards a player is dealt a 'hand' of cards from a pack of 52 different cards. The order in which the cards are received is irrelevant, the 'hand' consisting of the cards received, not the order in which they are received. How many different hands of seven cards are there?
- 7 A lottery competition involves selecting 6 numbers from 42. The method of selection makes repeat numbers impossible and the order of selection is irrelevant. How many different selections are possible?
- 8 Donelle makes a list of 15 people she would like to invite to her party but she is told that she must choose 10. How many different groups of 10 are possible?  
Having chosen the ten, and sent out the invitations, two of the chosen say they are unable to attend due to other commitments. She is allowed to choose two replacements from those in the 15 that she initially had to leave off the list.  
How many different replacement pairs are there?



iStock.com/Oleksandr Liptko



## More about Pascal's triangle

### Polygonal numbers

Placing dots into patterns that form triangles of increasing side length, as shown below, give us the sequence of triangular numbers, 1, 3, 6, 10, 15, ...

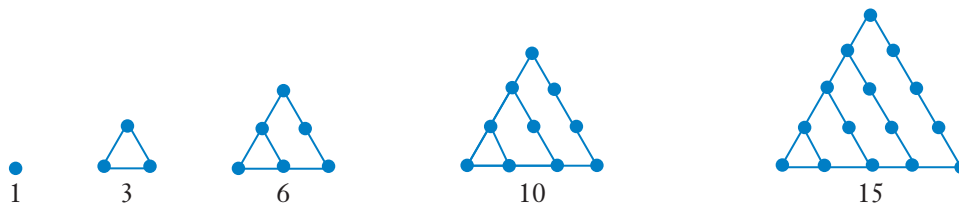

Notice that this sequence of triangular numbers also features in one of the diagonals of Pascal's triangle, as shown on the right.

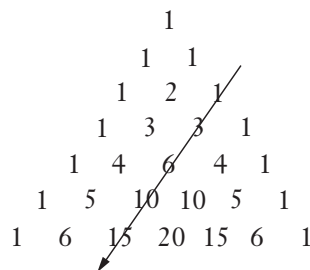

Now consider the sequence of square numbers:

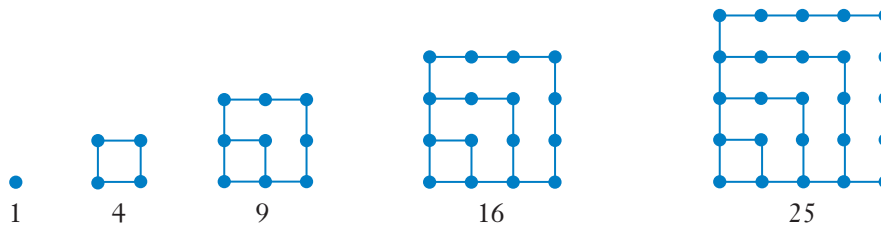

Can you see how the same diagonal of Pascal's triangle, by adding pairs of numbers, can give this sequence of square numbers?

Now consider the pentagonal numbers:

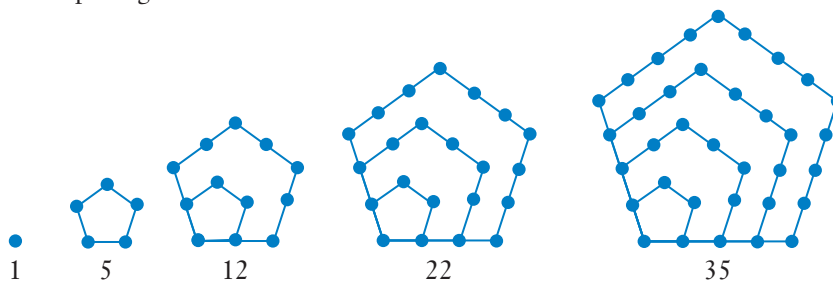

This time use the same diagonal of Pascal's triangle but now double the first number of the pair before adding it to the other.

The sequence of hexagonal numbers, not illustrated here, have the sequence

$$1, 6, 15, 28, 45, 66, \dots$$

Can you generate this sequence from that same diagonal?

### Row totals

If we define the second number in each row of Pascal's triangle as the row number then the row numbers would be as shown below left.

Row no.

0	1	= ??
1	1 + 1	= ??
2	1 + 2 + 1	= ??
3	1 + 3 + 3 + 1	= ??
4	1 + 4 + 6 + 4 + 1	= ??
5	1 + 5 + 10 + 10 + 5 + 1	= ??

What will be the sum of the numbers in the tenth row?

What will be the sum of the numbers in the twentieth row?

### Another number sequence

Suppose we first align Pascal's triangle somewhat differently:

1									
1	1								
1	2	1							
1	3	3	1						
1	4	6	4	1					
1	5	10	10	5	1				
1	6	15	20	15	6	1			
1	7	21	35	35	21	7	1		
1	8	28	56	70	56	28	8	1	

And then we 'step' the rows across, as shown below.

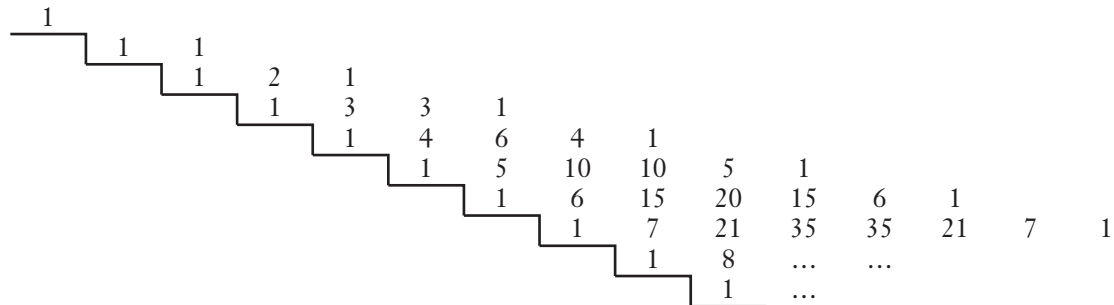

Now find the total for each completed column.

Recognise the sequence?

## Miscellaneous exercise ten

This miscellaneous exercise may include questions involving the work of this chapter, the work of any previous chapters, and the ideas mentioned in the Preliminary work section at the beginning of the book.

1 Solve each of the following equations.

a  $3x - 2 = 3 - 5x$

b  $3(2x + 1) = -5 + 4x$

c  $\frac{5x-3}{x-1} = 4$

d  $\frac{2x-1}{2-x} = 3$

e  $(x-3)(x+2) = 0$

f  $(x-1)(x+5) = 0$

g  $(2x-1)(x+7) = 0$

h  $(x+3)(4x-1)(5x-9) = 0$

i  $x^2 - 6x - 27 = 0$

j  $2x^2 - 3x - 14 = 0$

k  $x^3 - 5x^2 - 6x = 0$

l  $10x^2 - 7x - 12 = 0$

2 Determine the rule for each of the straight lines A to H shown in the graph below.

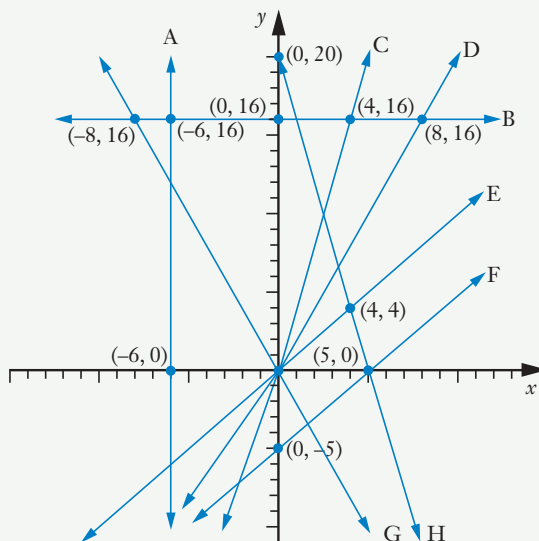

- 3 An event has only three possible outcomes, A, B and C, and these outcomes are mutually exclusive. If  $P(A) = 2p$ ,  $P(B) = 3p$  and  $P(C) = 5p$  determine  $p$ .
- 4 The product of three less than twice a number and seven more than double the number is zero. What could the number be?

- 5** From Lookout No.1 a fire is spotted on a bearing  $050^\circ$ . From Lookout No.2 the fire is seen on a bearing  $020^\circ$ . Lookout No.2 is 10 km from Lookout No.1 on a bearing  $120^\circ$ . Assuming that the fire and the two lookouts are all on the same horizontal level find how far the fire is from each lookout.



Getty Images/Spaces Images

- 6** For a particular experiment three possible outcomes, A, B and C are considered, at least one of these having to be the result. Outcomes A and B can occur together but C is mutually exclusive with A and with B. If  $P(A) = \frac{1}{2}$ ,  $P(B) = \frac{1}{2}$  and  $P(A \cap B) = \frac{1}{6}$ , determine  $P(C)$ .
- 7** Find the equation of the straight line
- with a gradient of 3 and cutting the  $y$ -axis at  $(0, 7)$
  - with a gradient of 3 and passing through the point  $(-1, 8)$
  - passing through  $(1, 5)$  and  $(3, 1)$
  - passing through  $(4, 8)$  and parallel to  $y + 2x = 7$
  - passing through  $(4, 8)$  and perpendicular to  $y + 2x = 7$
- 8** Solve the quadratic equation  $2x^2 + 1 = 4x$  using
- completing the square
  - the quadratic formula
- expressing your answers in exact form in each case.
- 9** Point  $M(5, 7)$  is the midpoint of the straight line AB. If point A has coordinates  $(12, 2)$  find the equation of the straight line that is perpendicular to  $2x + 3y = 5$  and passes through point B.
- 10** Two events X and Y are such that:  
 $P(X) = 0.6$ ,  $P(Y) = 0.4$ ,  $P(\overline{X \cap Y}) = 0.15$ ,  
 where  $P(X)$  is the probability of event X occurring.  
 Determine
- $P(X \cap Y)$
  - $P(\overline{Y})$
  - $P(X|\overline{Y})$
- 11** Two normal fair dice are rolled, one red and the other blue, and the two numbers obtained are added together.
- Event A is that of obtaining an even number with the blue die.
  - Event B is that of obtaining an even total.
  - Event C is that of the total obtained being 12.
- For each possible pair of events determine whether the events are independent or not.



iStock.com/Alliya23

- 13** If  $P(A) = \frac{3}{5}$  and  $P(B) = \frac{1}{3}$ , find  $P(\overline{A \cup B})$  in each of the following cases:
- A and B are mutually exclusive events
  - A and B are independent events.
- 14** Events A and B are such that  $P(A) = 0.6$ ,  $P(B|A) = 0.2$  and  $P(\overline{A \cup B}) = 0.32$ . Prove that A and B are independent events.
- 15** A person is randomly selected from the entire adult population of Australia. Event A is that of the randomly selected person being male. Event B is that of the randomly selected person being a professional rugby player. Determine, with explanation, whether A and B are independent events.
- 16** **a** Solve the equation  $2p^2 - p - 1 = 0$ .  
**b** Solve the equation  $2 \cos^2 x - \cos x - 1 = 0$  for  $-\pi \leq x \leq \pi$ .
- 17** If  $f(x) = 2x + 10$  and  $g(x) = x^2 - 3x - 4$  determine
- |   |  |                        |                          |
|---|--|------------------------|--------------------------|
| <b>a</b> $f(3)$                                 | <b>b</b> $f(-2)$                                   | <b>c</b> $g(0)$        | <b>d</b> $g(3)$          |
| <b>e</b> $g(-3)$                                | <b>f</b> $f(2) + g(2)$                             | <b>g</b> $f(x) + g(x)$ | <b>h</b> $f(2x) + g(2x)$ |
| <b>i</b> the values of $p$ for which $g(p) = 0$ | <b>j</b> the values of $q$ for which $f(q) = g(q)$ |                        |                          |
- 18** Given that all of the equations in the 'equations box' are shown graphed below (as unbroken lines) determine the values of  $a, b, c, d, e, f, g, h, j, k, m, n, p, q$  and  $r$  ( $i, l$  and  $o$  not used intentionally) of which all but two have integer values.

Equations box		
$y = ax + b$	$y = cx + 10$	$y = (x - d)^3$
$y = (x - e)^2 + f$	$y = (x - 1)(x - g)$	$y = \frac{h}{x}$

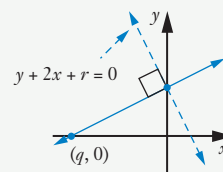
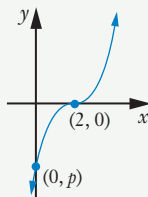
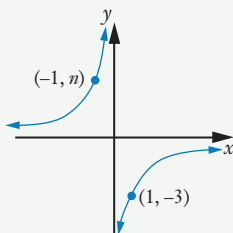
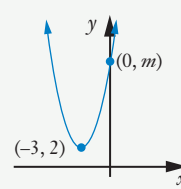
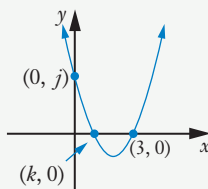
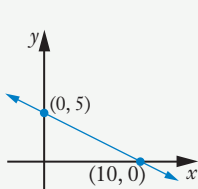

- 19** The graph below shows  $y = \cos ax$  and  $y = \cos [a(x + b)]$  for  $0 \leq x \leq 2\pi$ , and with  $a$  having the same integer value throughout and  $b$  being the smallest possible positive value.

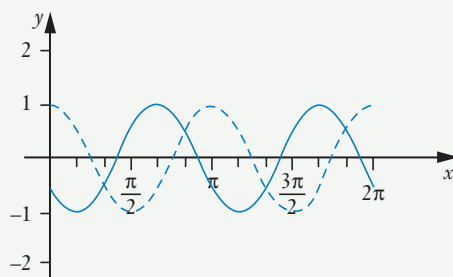

Find  $a$  and  $b$ .

- 20** A wheel of radius 60 cm is rotated until a point on the rim that was initially at the lowest point is 80 cm higher than its initial position. Find
- the angle in radians through which the wheel is rotated (correct to 2 decimal places)
  - the length of the circular path travelled by the point (to the nearest cm).
- 21** If  $\sin(x - y) = \cos x$  prove that  $\tan x = \frac{1 + \sin y}{\cos y}$ .

- 22** The display on the right shows the graph of

$$y = \frac{2x + 12}{x - 3}.$$

Without using a graphic calculator, determine the value of  $a$ , the value of  $b$  and the coordinates of points C and D.

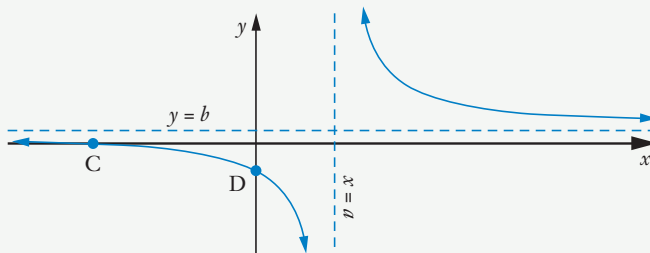

- 23** Express the equation of the function shown graphed below in the form  $y = a \sin bx + c$ .

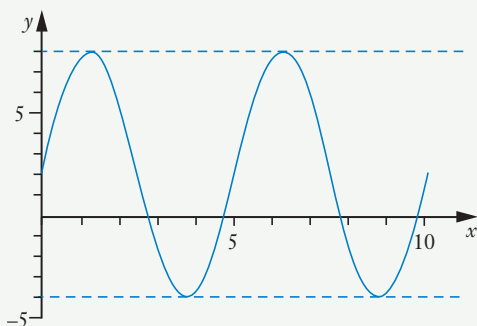



**24** Find  $y$ , shown in the diagram below, as an exact value.

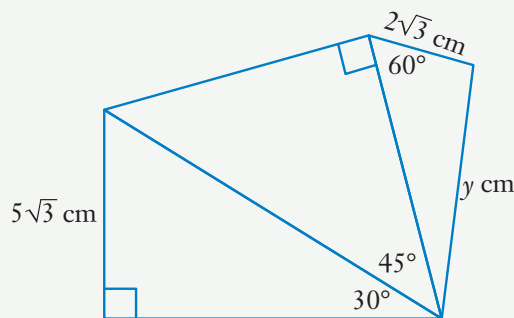

**25** Solve  $\sin 2x \cos x + \cos 2x \sin x = 0.5$  for  $0 \leq x \leq \pi$ .

**26** Expand and simplify  $(x - 2y)^6 + y^2(2x - y)^4$ .

**27** (Challenge)

The diagram shows how the vertical motion of a piston can be used to produce rotational motion. As the piston travels from the low position to the high position and back again the wheel will rotate. If the minor arc  $PQ$  is equal in length to  $r$ , the radius of the wheel, express  $x$  as a percentage of  $h$  correct to the nearest percent.

